

# ASP 250

Threaded

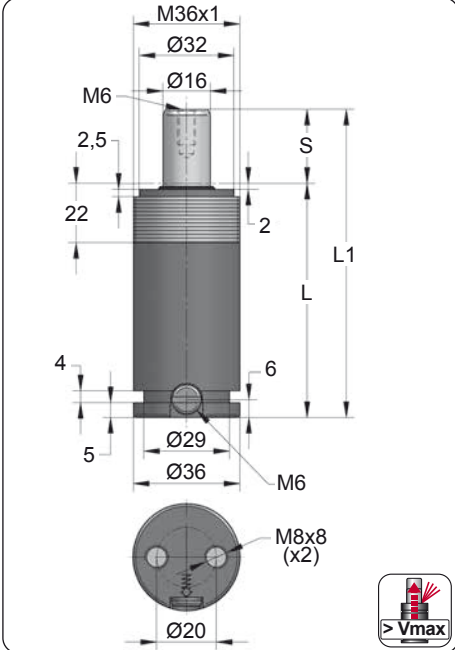

ORDER	S (mm)	L1 ±0,25 (mm)	L (mm)	Kg.
ASP 250 015	15	84	69	0.39
ASP 250 025	25	104	79	0.43
ASP 250 038	38	130	92	0.49
ASP 250 050	50	154	104	0.53
ASP 250 063	63.5	181	117.5	0.59
ASP 250 080	80	214	134	0.66
ASP 250 100	100	254	154	0.74

CODE				
	bar	psi	daN	daN
ASP 250 050	125	1810	250	340
-----	---	---	---	---

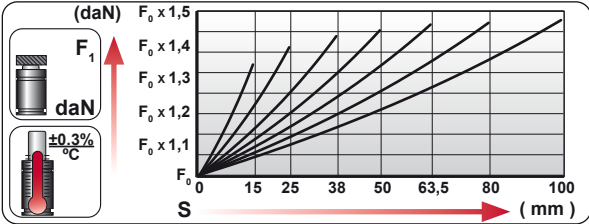
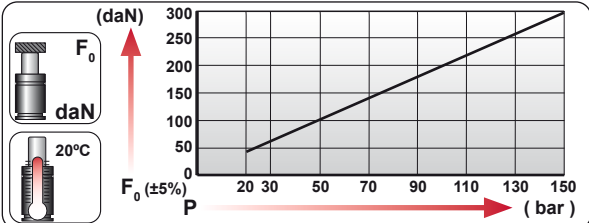

	ENG ORDER DEU BESTELLUNG FRA COMMANDE ITA ORDINE ESP PEDIDO POR PEDIDO		
		daN	mm
		ASP 250	50
		ASP 250 050	

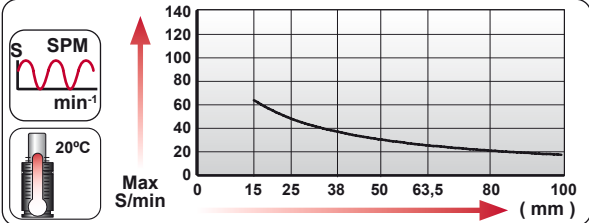

N <sub>2</sub>	S <sub>max</sub> < 90%	V <sub>max</sub> 1,6 m/s	P <sub>min</sub> (20°C)	P <sub>max</sub> (20°C)	T <sub>min</sub>	T <sub>max</sub>	

bar	psi	bar	psi	°C	°F	°C	°F	
20	290	150	2175	0	32	80	176	

**E03-036**

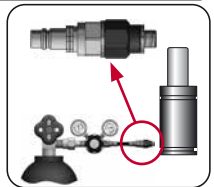
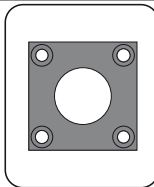
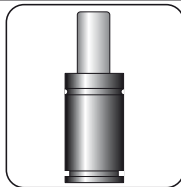
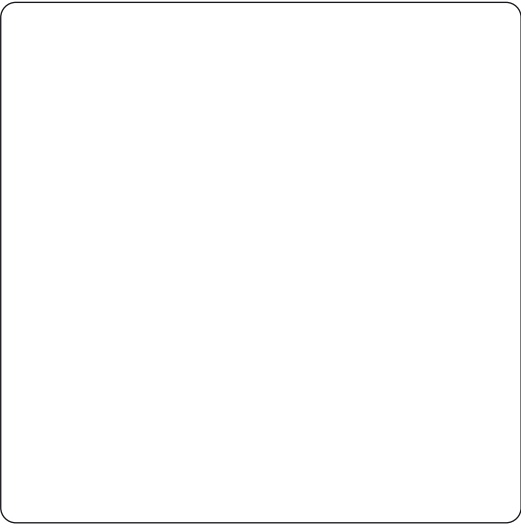
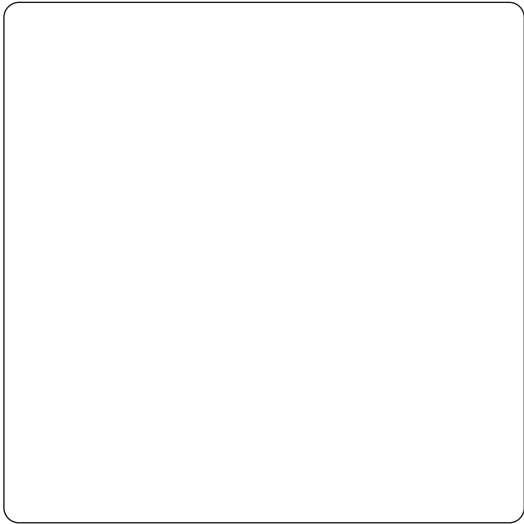
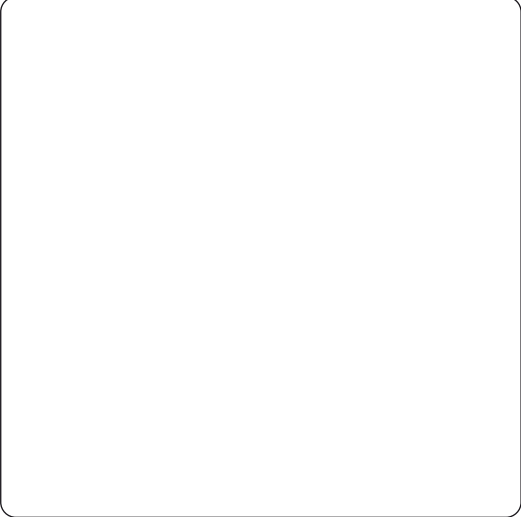
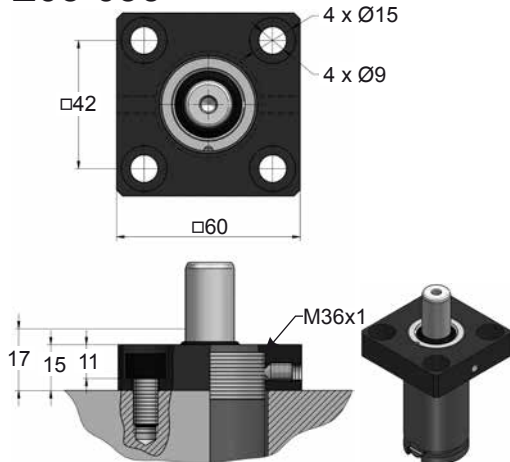

CODE	ASP 250 050	KIT S-XXXXXXX KIT C-XXXXXXX	E03-036	06 CG 2-Q
ENG ORDER	GAS SPRING	REPAIR KIT	FLANGE	CHARGING ADAPTER
DEU BESTELLUNG	GASDRUCKFEDER	ERSATZTEILSATZ	FLANSCHEN	LADEADAPTER
FRA COMMANDE	RESSORT À GAZ	KIT DE RÉPARATION	BRIDE	RACCORD DE CHARGE
ITA ORDINE	CILINDRO AD AZOTO	KIT DI MANUTENZIONE	FLANGE	ADATTATORE DI CARICO
ESP PEDIDO	RESORTE DE GAS	KIT DE REPARACION	BRIDA	ADAPTADOR DE CARGA
POR PEDIDO	CILINDRO DE GÁS	KIT DE MANUTENÇÃO	FLANGE	ADAPTADOR DE CARGA