

**ОПИСАНИЕ:**

**МАТЕРИАЛ:** 1.2842

**ТВЕРДОСТЬ:** 52-58 HRC

**ПРИМЕР ЗАКАЗА:** AC-КОД

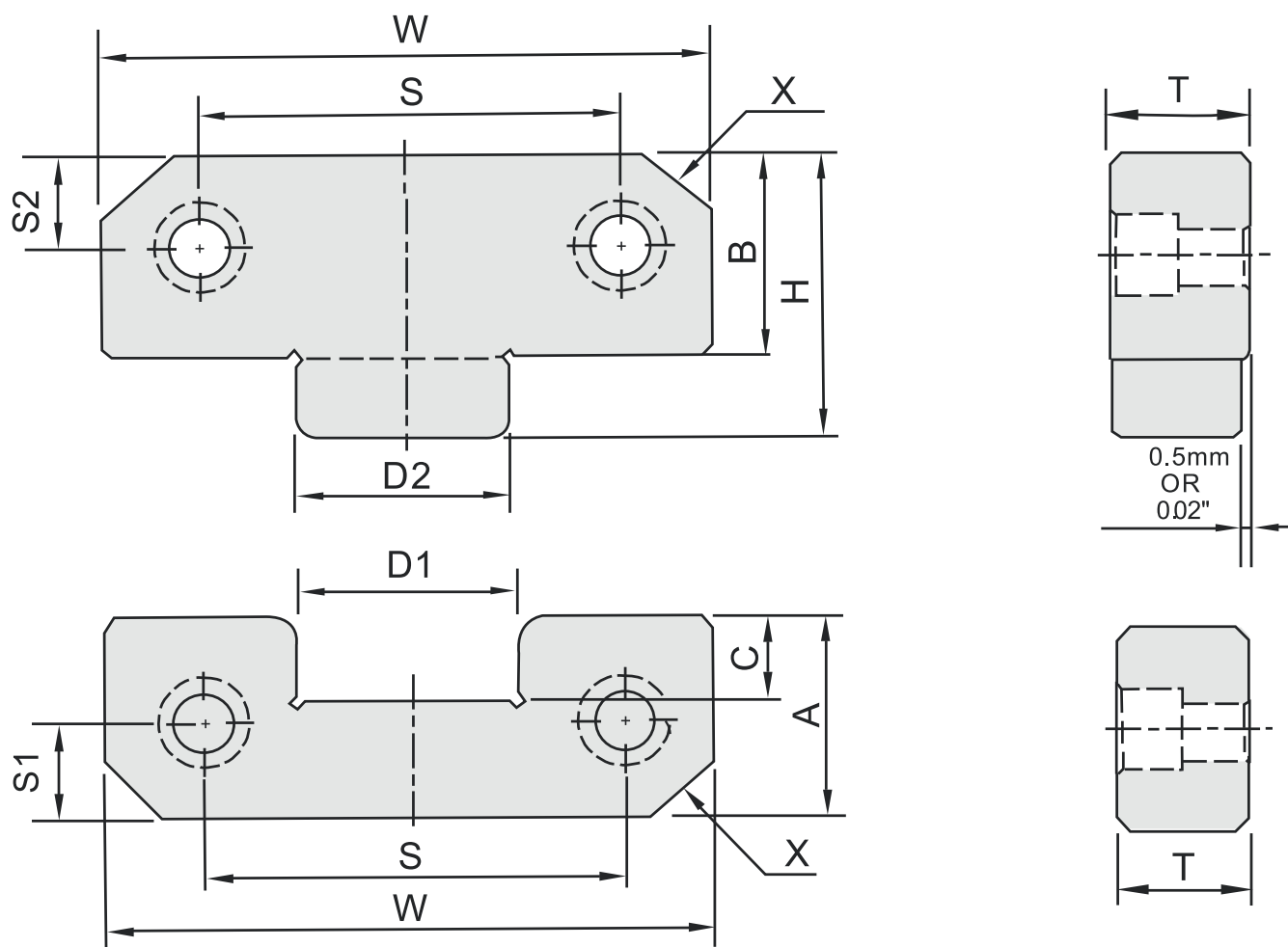

КОД	W 0 -0.01	T	A	B	C	D1 +0.0002 +0.0004	D2 0 -0.0002	H	S	S1	S2	X	SHCS
APL38	38	13	22	22	8.5	12	12	30	22	7	7	5	M6
APL50	50	16	21.5	21.5	9.5	17	17	30	34	11	11	5	M6
APL75	75	19	36	36	15	25	25	50	50	18	18	8	M10
APL100	100	19	45	45	21	35	35	65	70	22	22	10	M10
APL125	125	25	45	45	21	45	45	65	84	22	22	10	M10