

CPH 1250 V1

Heavy Load

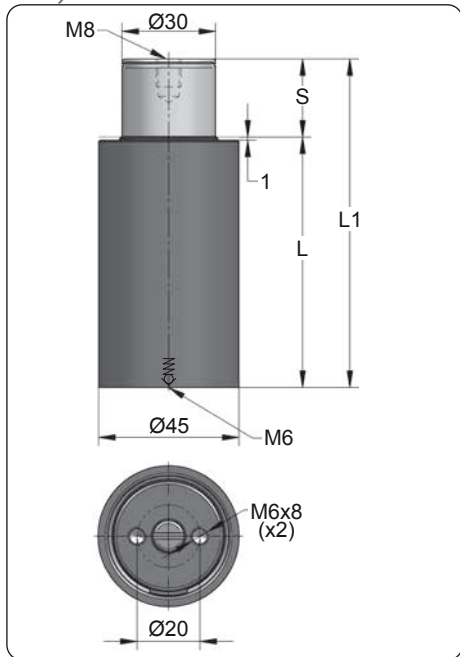

ORDER	S (mm)	L1 ±0,25 (mm)	L (mm)	Kg.
CPH 1250 012 V1	12	79	67	0.64
CPH 1250 025 V1	25	105	80	0.74
CPH 1250 038 V1	38	135	97	0.84
CPH 1250 050 V1	50	160	110	0.93
CPH 1250 063 V1	63	190	127	1.04
CPH 1250 080 V1	80	230	150	1.18

CODE				
		bar psi	daN	daN
CPH 1250 050 V1		170 2465	1200	2110
-----		-----	-----	-----

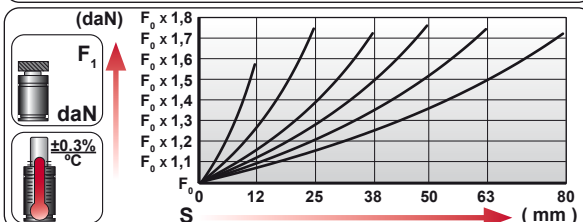
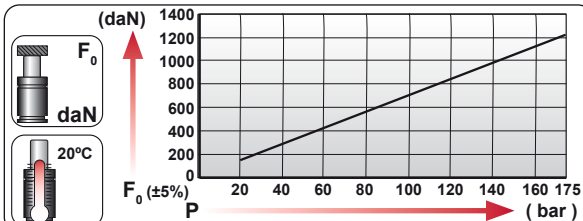

	ENG ORDER DEU BESTELLUNG FRA COMMANDE ITA ORDINE ESP PEDIDO POR PEDIDO		
		daN	mm
	CPH 1250 50		
	CPH 1250 050 V1		

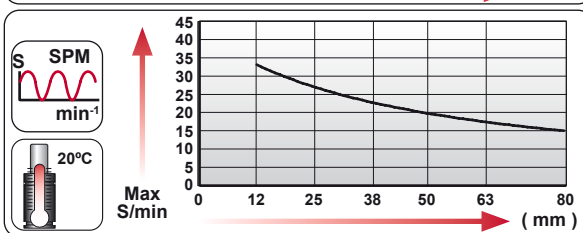

N ₂	S _{max} < 90%	V _{max} 0,5 m/s	P _{min} (20°C)	P _{max} (20°C)	T _{min}	T _{max}	

N ₂	S _{max} < 90%	V _{max} 0,5 m/s	bar psi	bar psi	°C °F	°C °F	°C °F	°C °F	
			20 290	175 2540	0 32	80 176			



CPH 1250 V1 MOUNTS

Heavy Load

s mm mm L1 mm	<p>50</p> <p>Ø45</p> <p>L1=132</p> <p>L1=147</p>	<p>50</p> <p>Ø45</p> <p>L1=138</p> <p>L1=150</p> <p>L1=150</p>	<p>50</p> <p>Ø45</p> <p>L1=160</p> <p>L1=185</p>	<p>50</p> <p>Ø45</p> <p>L1=185</p>	<p>50</p> <p>Ø45</p> <p>L1=160</p>	<p>50</p> <p>Ø45</p> <p>L1=160</p>	<p>50</p> <p>Ø45</p> <p>L1=160</p>	
MODEL	X	CW 750 KZ 750	X	CT 700 CK 750 FD 500	CM 600 CD 700	AG 500	CPH 1250	X
SERIES	MINI	COMPACT HEIGHT	THREADED	LOW PROFILE	HEAVY DUTY	ISO	HEAVY LOAD	POWER COMPACT STROKE

When using CP series mounted by screws the gas spring must be supported at all the times.
A flat support surface in contact with the whole surface of the gas spring body is always required.

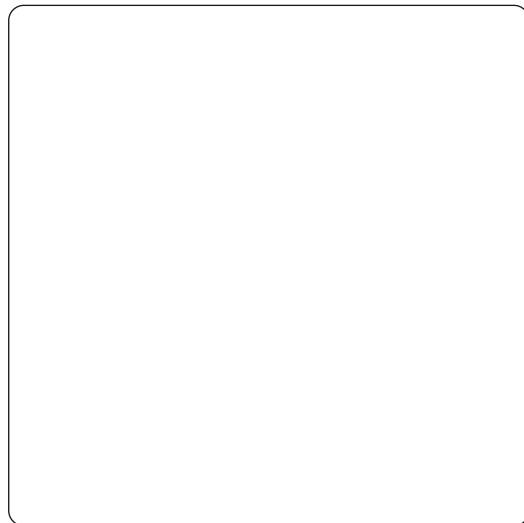

		<p>SEAL KIT S-XXXXXXX</p>		
--	--	---------------------------	--	--

CODE	CPH 1250 050 V1	KIT S-XXXXXXX	X	06 CG 2-Q
ENG ORDER	GAS SPRING	REPAIR KIT	FLANGE	CHARGING ADAPTER
DEU BESTELLUNG	GASDRUCKFEDER	ERSATZTEILSATZ	FLANSCHEN	LADEADAPTER
FRA COMMANDE	RESSORT À GAZ	KIT DE RÉPARATION	BRIDE	RACCORD DE CHARGE
ITA ORDINE	CILINDRO AD AZOTO	KIT DI MANUTENZIONE	FLANGE	ADATTATORE DI CARICO
ESP PEDIDO	RESORTE DE GAS	KIT DE REPARACION	BRIDA	ADAPTADOR DE CARGA
POR PEDIDO	CILINDRO DE GÁS	KIT DE MANUTENÇÃO	FLANGE	ADAPTADOR DE CARGA