

ПУАНСОНОДЕРЖАТЕЛЬ ДЛЯ ПУАНСОНА С ШАРИКОВЫМ КРЕПЛЕНИЕМ И ЦИЛИНДРИЧЕСКОЙ ГОЛОВКОЙ

ПРИМЕР ЗАКАЗА: Код HHS13

ПРИМЕР ЗАКАЗА ПОДКЛАДНОЙ/ПРИЖИМНОЙ ПЛАСТИНЫ: Код URSP1318

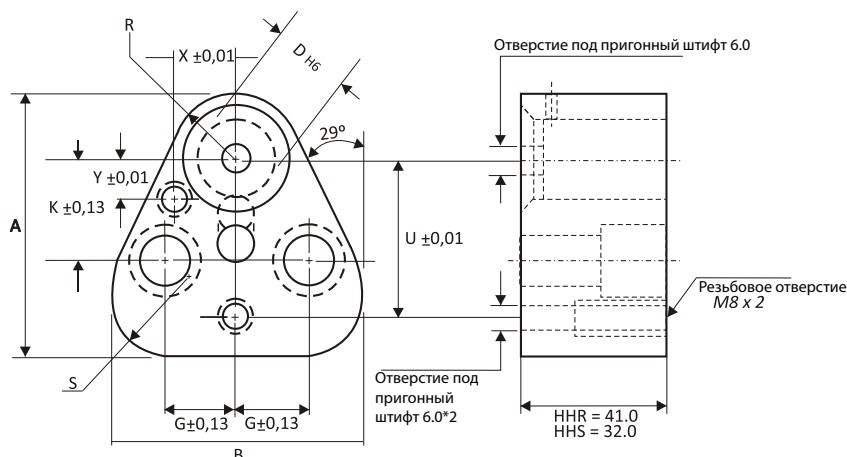

Код	D	A	B	G	K	R	S	U	X	Y	Резьба
HHS10	10	44,5	43,7	11,1	19,0	9,5	12,0	26,925	9,0	7,5	M8
HHS13	13	50,8	50,0	14,3	19,0	12,7	15,2	29,970	12,0	6,5	M8
HHS16	16	54,0	53,2	15,9	19,0	14,3	16,8	31,750	13,5	6,0	M8
HHS20	20	60,3	59,5	17,5	19,0	17,5	20,0	33,530	16,5	5,0	M10
HHS25	25	69,9	69,1	19,8	23,8	22,2	24,7	40,640	22,0	7,0	M12
HHS32	32	69,9	69,1	19,8	23,8	22,2	24,7	40,640	22,0	7,0	M12
HHS38	38	74,4	76,6	24,0	27,0	26,0	28,5	43,993	26,0	10,0	M12
HHS40	40	74,4	76,6	24,0	27,0	26,0	28,5	43,993	26,0	10,0	M12

D	КОД	
	1,8 (Мягкий)	4,8 (Rc55)
10	URSP1018	URBP1048
13	URSP1318	URBP1348
16	URSP1618	URBP1648
20	URSP2018	URBP2048
25	URSP2518	URBP2548
32	URSP3218	URBP3248

