

CW 1000 V2

Compact Height

BMW B2 4005	FORD W-DX35-6204	PSA E24.54.815.G
MB B8 3180 220 000 004	GM 90.25.08	
VW 39D 997		

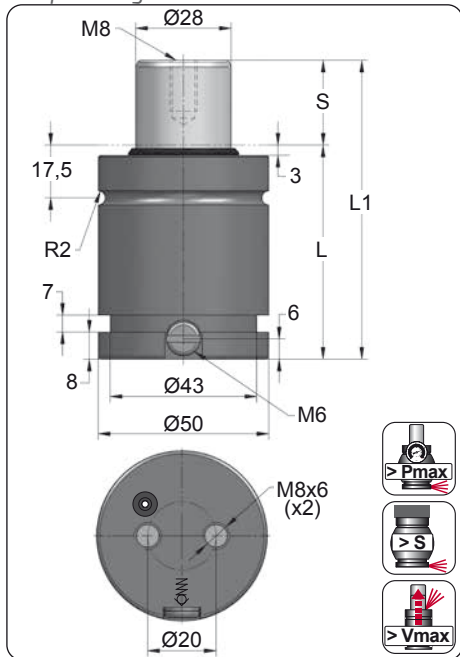

ORDER	S (mm)	L1 ±0.25 (mm)	L (mm)	Kg.
CW 1000 010 V2	10	58	48	0.53
CW 1000 013 V2	13	64	51	0.56
CW 1000 016 V2	16	70	54	0.58
CW 1000 019 V2	19	76	57	0.61
CW 1000 025 V2	25	88	63	0.66
CW 1000 032 V2	32	102	70	0.72
CW 1000 038 V2	38	114	76	0.77
CW 1000 050 V2	50	138	88	0.87
CW 1000 063 V2	63	164	101	0.98
CW 1000 075 V2	75	188	113	1.08
CW 1000 080 V2	80	198	118	1.12
CW 1000 100 V2	100	238	138	1.29
CW 1000 125 V2	125	288	163	1.50

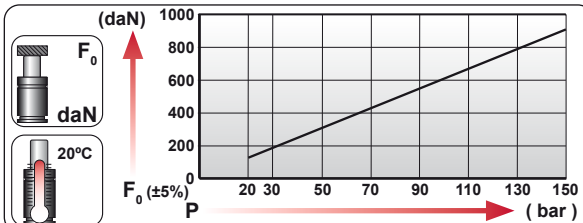

CODE	Pressure	Force F0	Force F1
	bar	psi	daN
CW 1000 050 V2	150	2175	920
CW-H 1000 050 V2	0	0	---

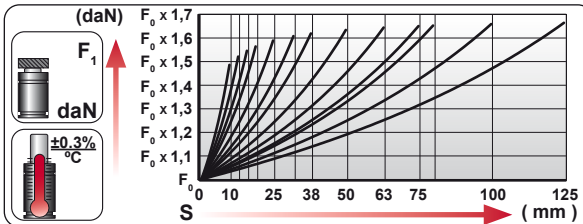

EQUIPPED WITH VDI - SAFETY

	ENG ORDER		
	DEU BESTELLUNG	daN	mm
	FRA COMMANDE		
	ITA ORDINE		
	ESP PEDIDO		
POR PEDIDO			
CW 1000 050 V2	1000	50	

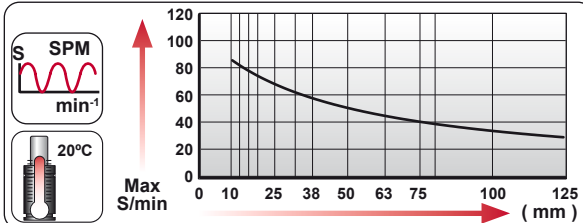

N ₂	S _{max} < 90%	V _{max} 1,6 m/s	P _{min} (20°C)	P _{max} (20°C)	T _{min}	T _{max}	600 CP-

bar	psi	bar	psi	°C	°F	°C	°F
20	290	150	2175	0	32	80	176

	L1=138 L1=152 L1=152	L1=138 L1=150 L1=150	L1=170 L1=185 L1=195	L1=195	L1=165 L1=175	L1=220		
MODEL	X	CW 1000 KZ 1000 KT 1000	X	CT 750 CK 1000 FD 750	GN 750 CM 1000 CD 1000	AG 750	CPH 1700 CP 2000	CS 1800
SERIES	MINI	COMPACT HEIGHT	THREADED	LOW PROFILE	HEAVY DUTY	ISO	HEAVY LOAD	POWER COMPACT STROKE

CW		CWC	
	KRM6 		DRM8
	BK 		TNRR
			9RM8
			MCRR
			7RM8
			TFRR
			SKK
			SGS

		SEAL KIT S-XXXXXXX	CARTRIDGE KIT C-XXXXXXX		

CODE	CW 1000 050 V2	KIT S-XXXXXXX KIT C-XXXXXXX	A14-050	06 CG 2-Q
ENG	ORDER	GAS SPRING	REPAIR KIT	FLANGE
DEU	BESTELLUNG	GASDRUCKFEDER	ERSATZTEILSATZ	FLANSCH
FRA	COMMANDE	RESSORT À GAZ	KIT DE RÉPARATION	BRIDE
ITA	ORDINE	CILINDRO AD AZOTO	KIT DI MANUTENZIONE	FLANGE
ESP	PEDIDO	RESORTE DE GAS	KIT DE REPARACION	BRIDA
POR	PEDIDO	CILINDRO DE GÁS	KIT DE MANUTENÇÃO	FLANGE
				CHARGING ADAPTER
				LADEADAPTER
				RACCORD DE CHARGE
				ADATTATORE DI CARICO
				ADAPTADOR DE CARGA
				ADAPTADOR DE CARGA