

CA.FN

. Blades FN

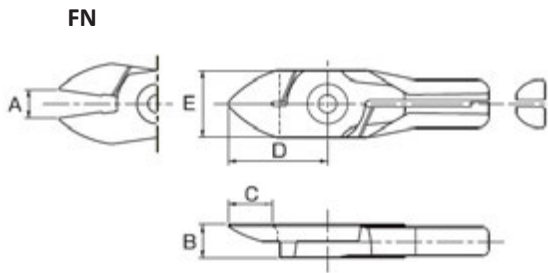

Article no.	M	A	B	C	D	E	Cutting capacity	Weight
CA.FN10	CA.SN3	3.5	7	11	24	14	∅ 2	25 g
CA.FN1	CA.SN5	5.5				16	∅ 3	30 g
CA.FN3	CA.SN10	7	9		27	19	∅ 4	60 g
CA.FN5	CA.SN20	8.5	12	16	35	22	∅ 5	100 g

Table / Tabelle

M = Suitable for CA.SN...

Passend für CA.SN...

. Schneideinsätze FN

FN

FNP

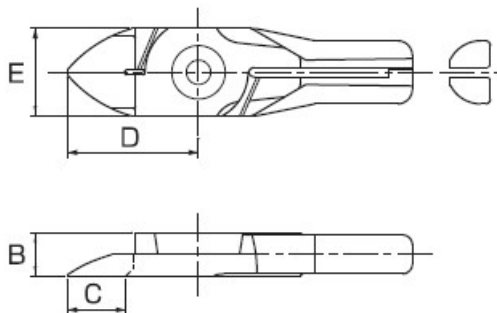

Article no.	M	A	B	C	D	E	Cutting capacity	Weight
CA.FNP10	CA.SNP3	3.5	7	11	24	14	∅ 2	30 g
CA.FNP1	CA.SNP5	5.5				16	∅ 3	35 g
CA.FNP3	CA.SNP10	7	9		27	19	∅ 4	60 g
CA.FNP5	CA.SNP20	8.5	12	16	35	22	∅ 5	110 g

Table / Tabelle

M = Suitable for CA.SN...

Passend für CA.SN...

FN - K

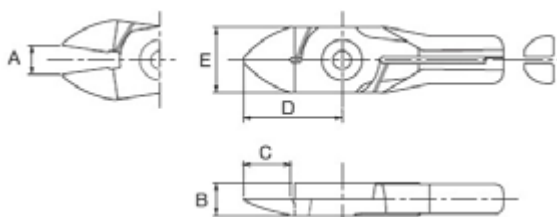

Article no.	M	A	B	C	D	E	Cutting capacity	Weight
CA.FN10K	CA.SN3	3.5	7	11	24	14	∅ 2	30 g
CA.FN1K	CA.SN5	5.5				16	∅ 3	
CA.FN3K	CA.SN10	7.5	9		27	19	∅ 4	60 g
CA.FN5K	CA.SN20	8.5	12	16	35	22	∅ 5	110 g

Table / Tabelle

M = Suitable for CA.SN...

Passend für CA.SN...

FN - L

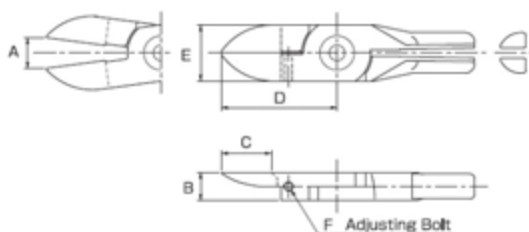

Article no.	M	A	B	C	D	E	F	Cutting capacity	Weight
CA.FN10L	CA.SN3	5.5	7	16	33	14	M3	∅ 2	35 g
CA.FN1L	CA.SN5	8				16		∅ 3	40 g
CA.FN3L	CA.SN10	9.5	9		37	18		∅ 3.5	65 g
CA.FN5L	CA.SN20	10	12	21	45	22		∅ 4.5	115 g

Table / Tabelle

M = Suitable for CA.SN...

Passend für CA.SN...