

CT 200 V2

Low Profile

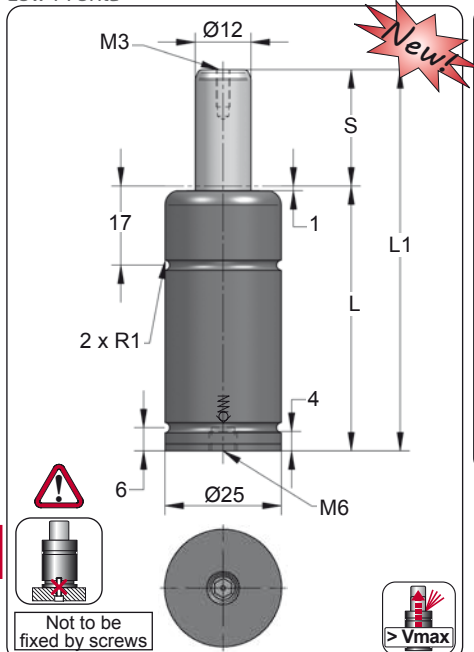

ORDER	S (mm)	L1 ±0,25 (mm)	L (mm)	Kg.
CT 200 007 V2	7	46	39	0.11
CT 200 010 V2	10	52	42	0.12
CT 200 012 V2	12.7	57.4	44.7	0.12
CT 200 016 V2	16	64	48	0.13
CT 200 019 V2	19	70	51	0.13
CT 200 025 V2	25	82	57	0.15
CT 200 032 V2	32	96	64	0.16
CT 200 038 V2	38	108	70	0.17
CT 200 050 V2	50	132	82	0.19
CT 200 063 V2	63.5	159	95.5	0.22
CT 200 080 V2	80	192	112	0.25
CT 200 100 V2	100	232	132	0.29



CODE				
		bar psi	daN	daN
CT 200 050 V2		180 2610	200	295
-----		-----	-----	-----

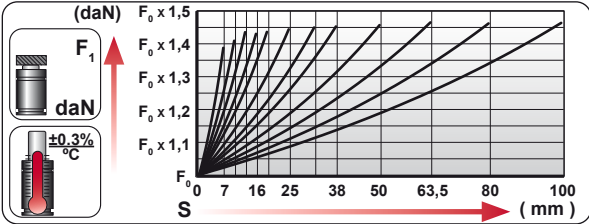
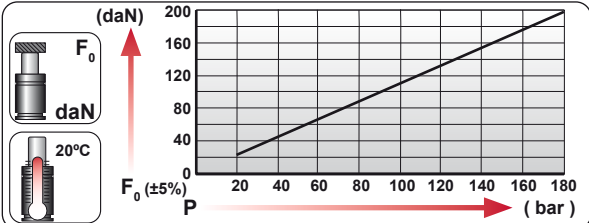

	ENG ORDER DEU BESTELLUNG FRA COMMANDE ITA ORDINE ESP PEDIDO POR PEDIDO		
		daN	mm
		CT 200	50
		CT 200 050 V2	

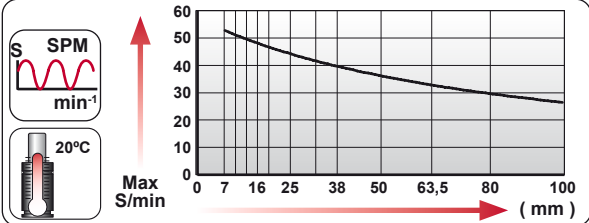

N ₂	S _{max} < 90%	V _{max} 1,6 m/s	P _{min} (20°C)	P _{max} (20°C)	T _{min}	T _{max}	

N ₂	S _{max} < 90%	V _{max} 1,6 m/s	bar psi	bar psi	°C °F	°C °F	°C °F	
			20 290	180 2610	0 32	80 176		

CT 200 V2 MOUNTS

Low Profile

A14-025

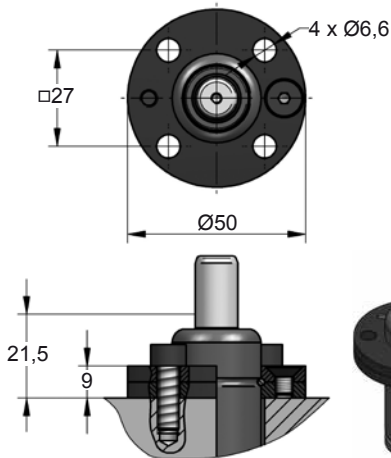

A19-025

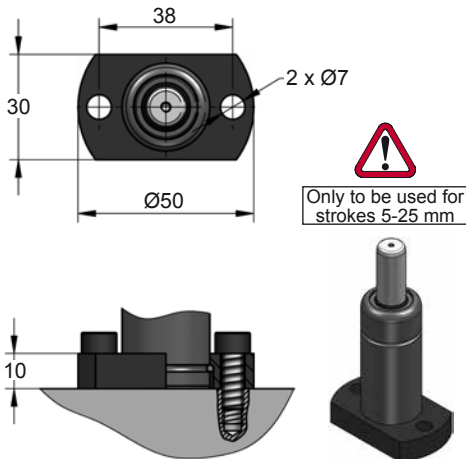

A44-025

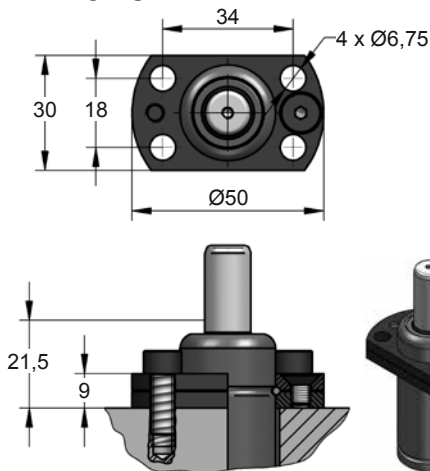

A49-025

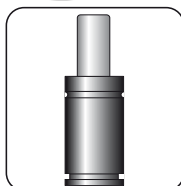
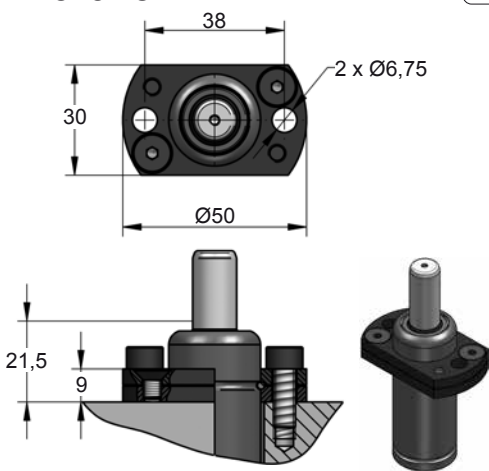

SEAL
KIT S-XXXXXXX

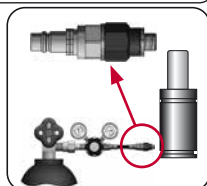
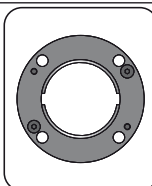

CODE	CT 200 050 V2	X	A14-025	06 CG 2-Q
ENG ORDER	GAS SPRING	REPAIR KIT	FLANGE	CHARGING ADAPTER
DEU BESTELLUNG	GASDRUCKFEDER	ERSATZTEILSATZ	FLANSCHEN	LADEADAPTER
FRA COMMANDE	RESSORT À GAZ	KIT DE RÉPARATION	BRIDE	RACCORD DE CHARGE
ITA ORDINE	CILINDRO AD AZOTO	KIT DI MANUTENZIONE	FLANGE	ADATTATORE DI CARICO
ESP PEDIDO	RESORTE DE GAS	KIT DE REPARACION	BRIDA	ADAPTADOR DE CARGA
POR PEDIDO	CILINDRO DE GAS	KIT DE MANUTENÇÃO	FLANGE	ADAPTADOR DE CARGA