

ASP 500 V1

Threaded

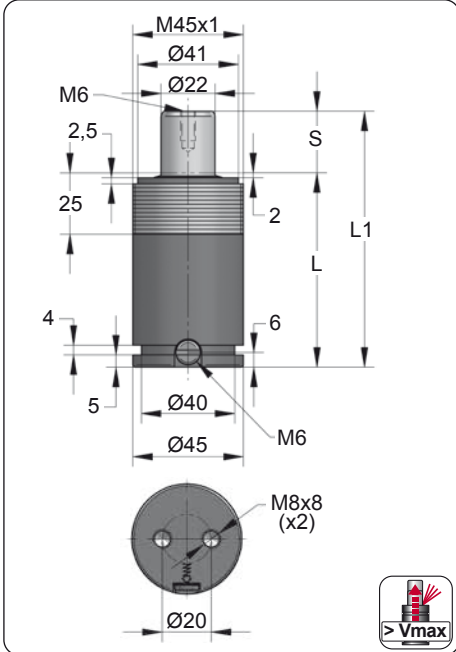

ORDER	S (mm)	L1 ±0,25 (mm)	L (mm)	Kg.
ASP 500 015 V1	15	84	69	0.56
ASP 500 025 V1	25	104	79	0.62
ASP 500 038 V1	38	130	92	0.70
ASP 500 050 V1	50	154	104	0.77
ASP 500 063 V1	63.5	181	117.5	0.86
ASP 500 080 V1	80	214	134	0.96
ASP 500 100 V1	100	254	154	1.09

CODE				
		bar psi	daN	daN
ASP 500 050 V1		130 1885	495	705
-----		---	---	---

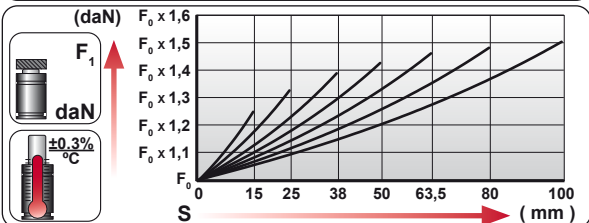
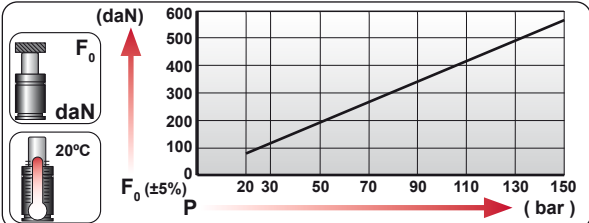

	ENG ORDER		
	DEU BESTELLUNG	daN	mm
	FRA COMMANDE		
	ITA ORDINE		
	ESP PEDIDO		
POR PEDIDO			

ASP 500 50

ASP 500 050 V1

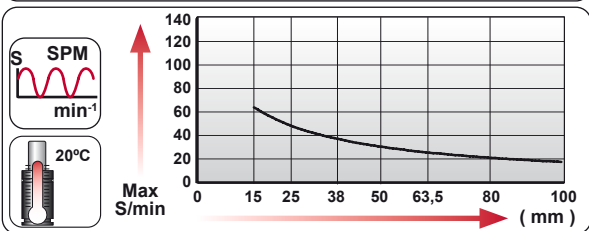

N ₂	S _{max} < 90%	V _{max} 1,6 m/s	P _{min} (20°C)	P _{max} (20°C)	T _{min}	T _{max}	

bar psi	bar psi	°C °F	°C °F	
20 290	150 2175	0 32	80 176	

E03-045

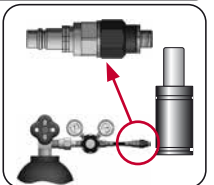
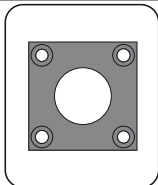
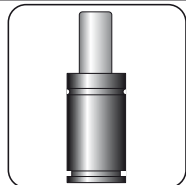
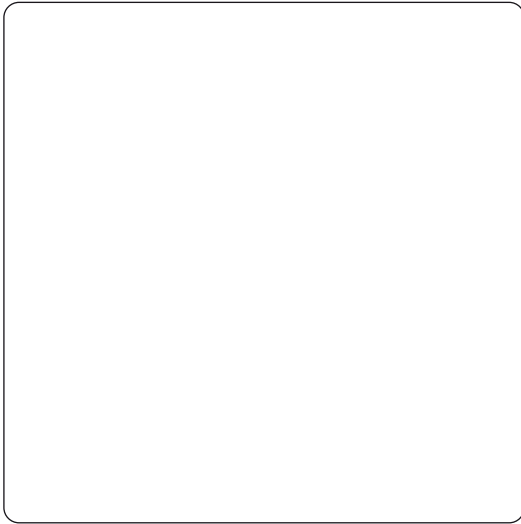
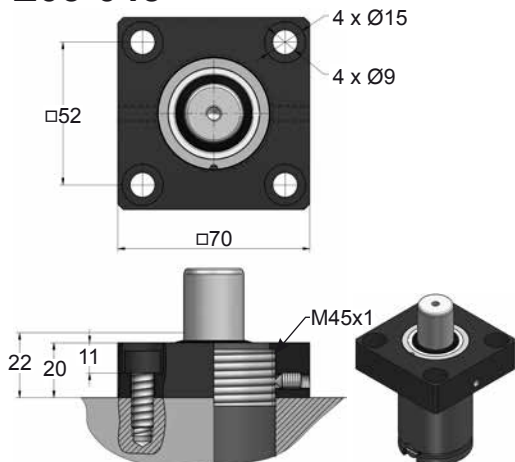

CODE	ASP 500 050 V1	KIT S-XXXXXXX KIT C-XXXXXXX	E03-045	06 CG 2-Q
ENG ORDER	GAS SPRING	REPAIR KIT	FLANGE	CHARGING ADAPTER
DEU BESTELLUNG	GASDRUCKFEDER	ERSATZTEILSATZ	FLANSCHEN	LADEADAPTER
FRA COMMANDE	RESSORT À GAZ	KIT DE RÉPARATION	BRIDE	RACCORD DE CHARGE
ITA ORDINE	CILINDRO AD AZOTO	KIT DI MANUTENZIONE	FLANGE	ADATTATORE DI CARICO
ESP PEDIDO	RESORTE DE GAS	KIT DE REPARACION	BRIDA	ADAPTADOR DE CARGA
POR PEDIDO	CILINDRO DE GÁS	KIT DE MANUTENÇÃO	FLANGE	ADAPTADOR DE CARGA