

## CA.09 BVAE

. Movable vacuum unit BVAE32  
with guided double stroke

## BVAE

. Bewegliche Vakuumeinheit BVAE32  
mit Doppelhub geführt

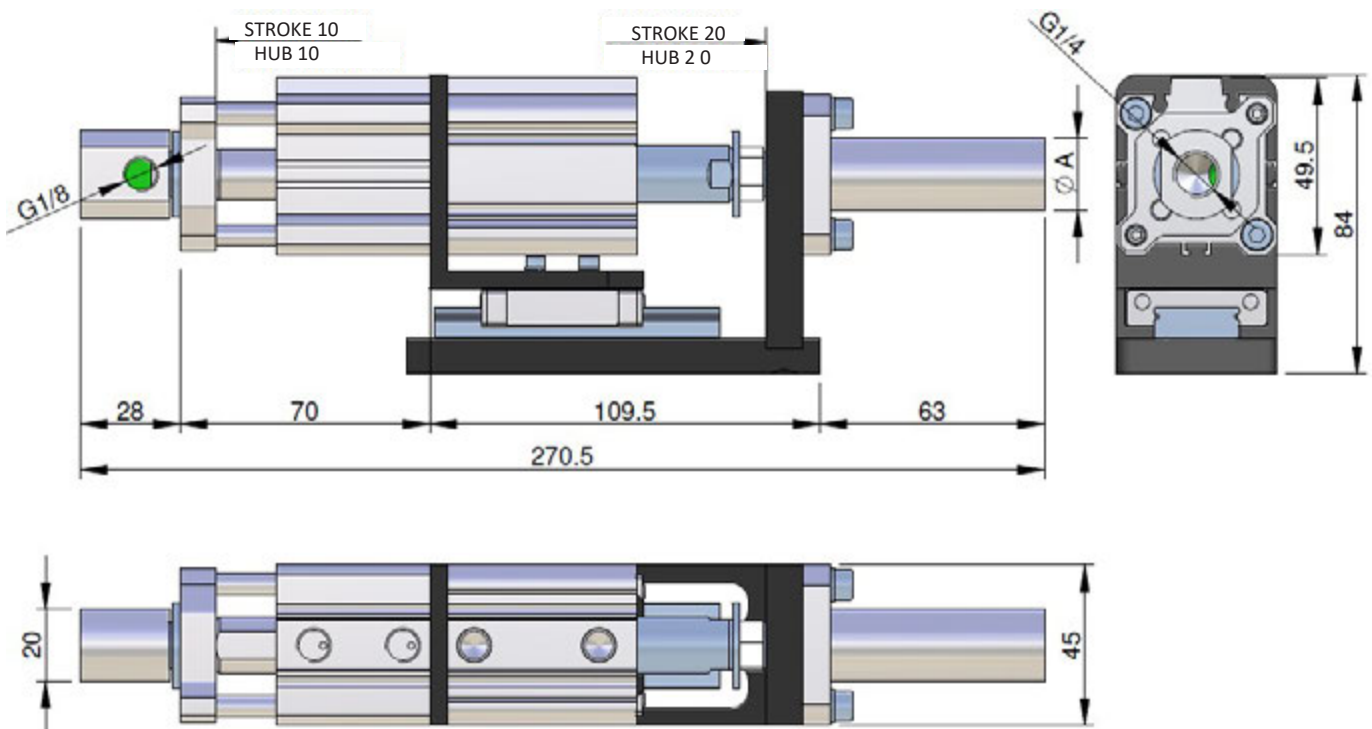
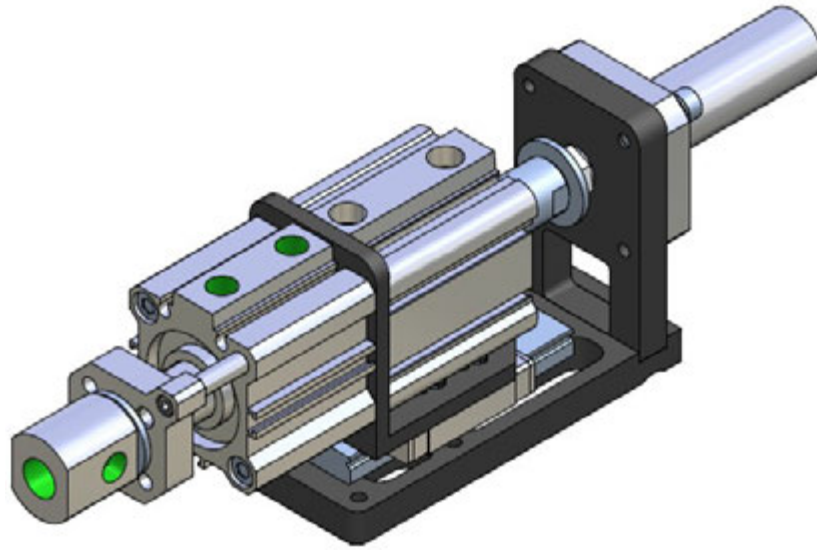

Article no.	A	Weight
CA.BVAE.32201020	20	1043 g
CA.BVAE.32201025	25	1073 g