

CA.10.F

. F

. Blades

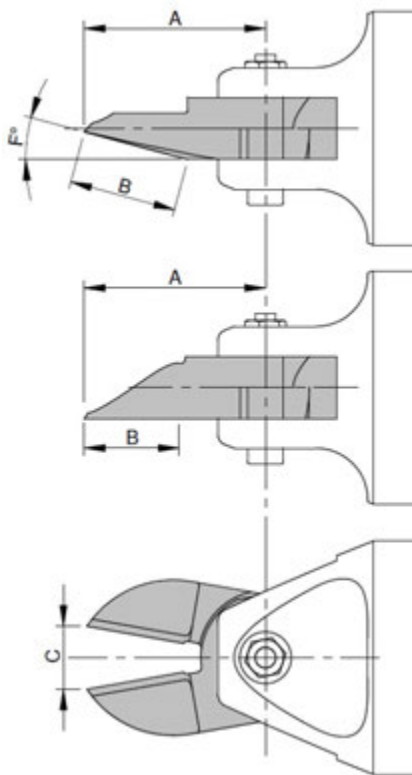

. Schneideinsätze

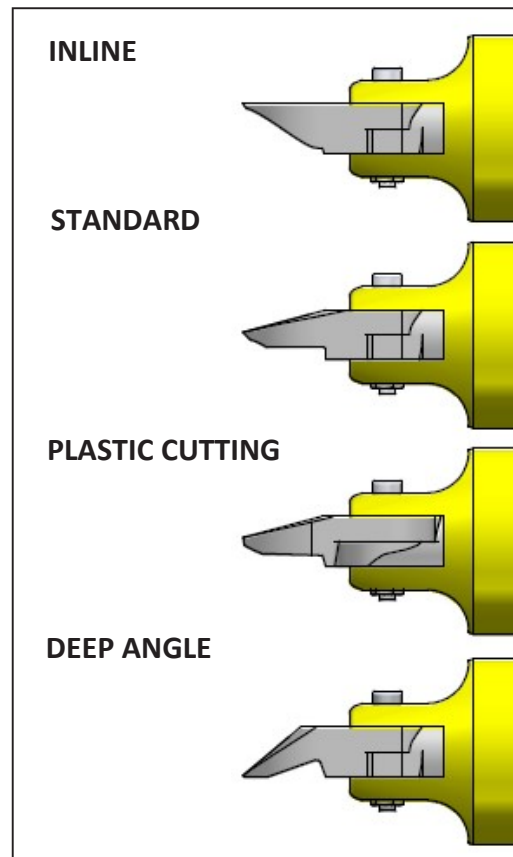

Article no.		Nipper	Blade style	A	B	C	F°	Weight
CA.F1S	F..S	CA.MR.05M	Inline	24	12	3	/	33 g
CA.S2	S..		Standard				25	34 g
CA.F1	F..		Platic cutting				15	
CA.FD1	F..D		Deep angle				40	35 g
CA.F3LS	F..S	CA.MR.10M	Long Inline	50	30	8	/	117 g
CA.S4	S..		Standard	27	14	5	25	115 g
CA.F3	F..		Platic cutting		12			
CA.FD3	F..D		Deep angle		10		40	112 g
CA.F5S	F..S	CA.MR.20M	Inline		35		16	10
CA.S5	S..		Standard	17		8	30	120 g
CA.F5	F..		Platic cutting	15		10	15	
CA.FD5	F..D		Deep angle	14		40	124 g	
CA.F5LS	F..S		Long inline	65		37	15	/
CA.F9PS	F..S	CA.MR.30AM	Inline	66	37	16	/	365 g
CA.S7P	S..		Standard	43	20	8	30	380 g
CA.F9P	F..		Platic cutting	66	38	16	16	
CA.FD9P	F..D		Deep angle	59	27	15	30	388 g
CA.S120	S..	CA.MR.50AM	Standard	45	22	10	30	380 g